

BI-620 Industrial pH Controller

USER MANUAL

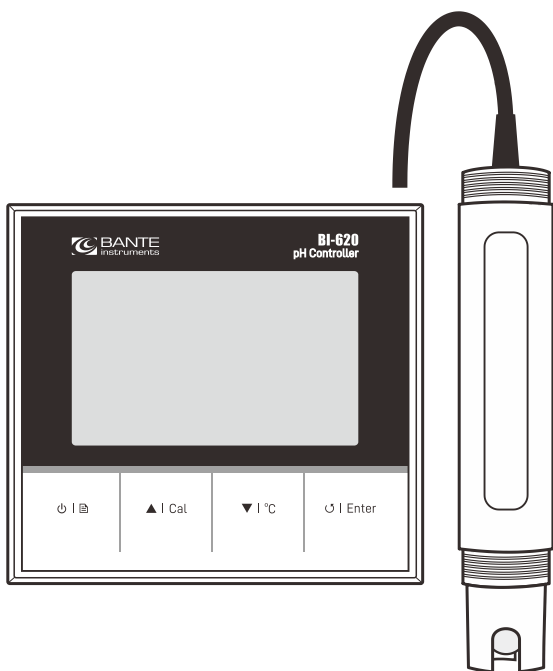

Introduction

Thank you for selecting the BI-620 industrial pH controller. This user manual provides a step-by-step guide to help you operate the meter, please carefully read the following instructions before use.

Environmental Conditions

Before the installation, ensure that current environmental conditions meet the following requirements.

- Relative humidity is less than 80%
- Ambient temperature between 5°C (41°F) and 50°C (122°F)
- No potential electromagnetic interference
- No corrosive gas exists

Packing List

The following list describes all components of the meter. If any items are missing or damaged, contact the supplier immediately.

BI-620 pH controller

IE-20T industrial pH electrode

pH buffer reagents 4.01, 7.00, 10.01

Installation

Safety Warning

- BI-620 meter shall be installed and operated only in the manner specified in this user manual.
- Only skilled, trained or authorized person should carry out installation, setup and operation of meter.



- The rear panel of meter has two screw terminals for connecting the 24V DC power supply. Make sure to cut off the main power before installation and maintenance.
- Once the power supply cable is connected to the meter, DO NOT touch any screw terminals.

Installing the Meter

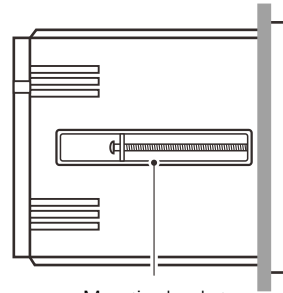
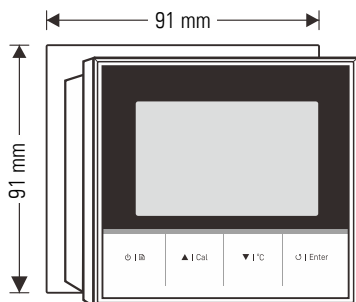

Mounting bracket

- 1.1 Cut out a square hole approximately 91 × 91 mm (3.58 × 3.58 in.) in the mounting panel.
- 1.2 Remove the mounting bracket, place the meter into the square hole.
- 1.3 Replace the mounting bracket and push the meter forward until it is fully seated on the mounting plate.

Installing the Electrode

- 2.1 Remove the protective cap from the bottom of the pH electrode. If tiny air bubbles are present inside the pH-sensitive glass membrane, gently shake the electrode downward to remove air bubbles.
- 2.2 Wrap Teflon tape to the electrode body threads.
- 2.3 Insert the electrode into the mounting position and slowly turn clockwise until secure. Hand tighten the electrode to prevent liquid leakage.

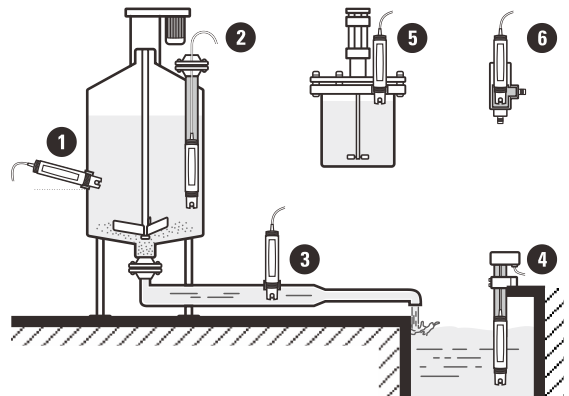

Selectable Mounting Positions:

- 1 Side wall mounting (Note: the electrode must be positioned at least 15° up from horizontal)
- 2 Flange mounting
- 3 Pipe mounting
- 4 Immersion mounting
- 5 Top mounting
- 6 Flow cell mounting

Connection

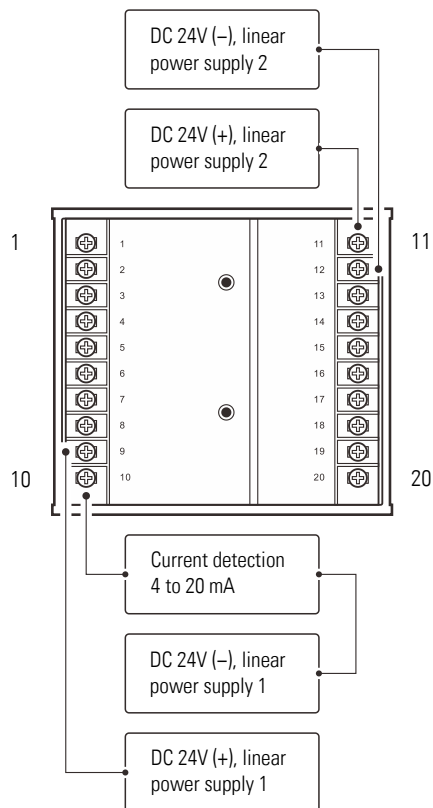

No.	Terminal	Description
1	pH (-)	pH/mV input (reference)
2	pH (+)	pH/mV input (measurement)
3	---	No connection
4	---	No connection
5	TC (-)	Temperature input (-)
6	TC (+)	Temperature input (+)
7	485 (B)	RS485 signal output (B)
8	485 (A)	RS485 signal output (A)
9	DC 24 (+)	DC 24V (+), linear power supply 1
10	DC 24 (-)	DC 24V (-), linear power supply 1 4 to 20 mA analog output
11	GND	Earth ground
12	DC 24 (+)	DC 24V (+), linear power supply 2

13	DC 24 (-)	DC 24V (-), linear power supply 2
14	NC2	Relay resting position (NC2)
15	NO2	Relay working position (NO2)
16	COM2	Relay common (COM2)
17	NC1	Relay resting position (NC1)
18	NO1	Relay working position (NO1)
19	COM1	Relay common (COM1)
20	---	No connection

Meter Overview

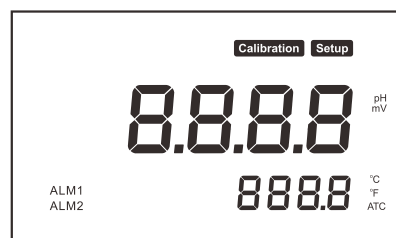

Display

Icon	Description
Calibration	Indicates that the meter is in the calibration mode
Setup	Indicates that the meter is in the setup mode
ATC	Indicates that the automatic temperature compensation is enabled
ALM1	Indicates the measurement exceeded the high limit
ALM2	Indicates the measurement exceeded the low limit

Keypad

Key	Function
⏻ 🏠	<ul style="list-style-type: none"> Switch the meter on or off Press and hold the key to enter the setup menu Exit the calibration, settings and return to the measurement mode
▲ Cal	<ul style="list-style-type: none"> Start calibration Increase value or scroll up the menu items
▼ °C	<ul style="list-style-type: none"> Set the temperature Decrease value or scroll down the menu items
↻ Enter	<ul style="list-style-type: none"> Toggle between the pH and mV modes Confirm the calibration, setting or displayed option

Meter Setup

The BI-620 meter contains an integrated setup menu for customizing the displayed option to meet measurement requirement. The following table describes the functions of each menu item.

Menu Item	Option and Description
bUF	pH Buffer Group Set the pH buffer group for calibration and auto-recognition.
	USA USA (default)
	NIST NIST
CAL	Calibration Points Set the number of calibration points.
	1 1 point
	2 2 points (default)
UNIT	Temperature Unit
	°C Degrees Celsius (default) °F Degrees Fahrenheit
AL-L	Low Alarm Limit Setting range: 1.00 to 10.00 pH (default 1.00 pH)
	High Alarm Limit Setting range: 10.00 to 1.00 pH (default 10.00 pH)
AL-H	Hysteresis Value Setting range: 0.01 to 1.00 pH (default 0.01 pH)
	Analog Output (Low) Setting range: 0.00 to 14.00 pH (default 0.00 pH)
AL-L	Analog Output (High) Setting range: 14.00 to 0.00 pH (default 14.00 pH)
	Factory Reset Reset the meter to factory default settings. Note, the meter must be recalibrated.
RST	YES Enable
	NO Disable (default)



- If the high or low alarm is enabled, the meter will be activated when the measurement exceeds specified limit. Note, this option can not enter the same values.
- If the hysteresis is enabled, the meter will prevent rapid contact switching when the measurement is fluctuating near the set point. For example, you have set the high alarm at 14.00 pH and hysteresis value at 0.1 pH. When the measurement overshoots the 14.1 pH, the meter will activate an external device. When the measurement drops to 13.9 pH, the device will switch off.
- The default RS485 communication is 0 to 14.00 pH corresponds to the 4.00 to 20.00 mA.

Setting a Default Option

- In the measurement mode, press and hold the key to enter the setup menu.
- Press the key to select a menu item, press the **Enter** key to confirm.



- Press the key to select an option or set a value, press the **Enter** key to save.

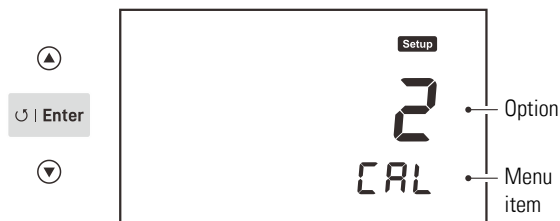

To exit the setup menu without saving changes, press the key.

Temperature Compensation

The BI-620 meter is supplied with an industrial pH electrode. When the wires of electrode are connected to the meter, the display will show ATC icon immediately. The meter is now switched to the automatic temperature compensation mode.

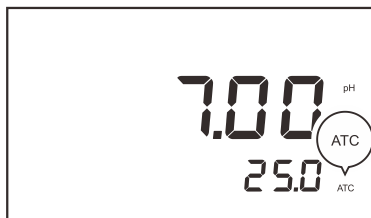

Temperature Calibration

During the measurement, if the measured temperature reading differs from that of an accurate thermometer, the electrode needs to be calibrated.

1. Place the electrode into a solution with a known accurate temperature.
2. Press the **°C** key to enter the temperature setting.
3. Press the **▲ / ▼** key to modify the temperature value.
4. Press the **Enter** key to save.



pH Calibration

The BI-620 meter allows up to 3 points pH calibration. We recommend that you perform at least 2 points calibration for high accuracy measurement. The meter will automatically recognize and calibrate to following standard buffer values.

USA Standard Buffers	pH 4.01, 7.00, 10.01
NIST Standard Buffers	pH 4.01, 6.86, 9.18

Single point calibration should only be carried out with the pH 7.00 or 6.86, otherwise calibration will not be accepted.

Make sure to calibrate the meter when attaching a new pH electrode or during first use. Do not reuse the buffer solutions after calibration, contaminants in solution will affect the calibration and eventually the accuracy of the measurement.

Single Point Calibration

- 1.1 Ensure that the meter is in the pH measurement mode and you have selected 1 point calibration in the setup menu.
- 1.2 Press the **Cal** key, the meter shows **7.00 / CAL 1** or **6.86 / CAL 1**, depending on the selected pH buffer group.

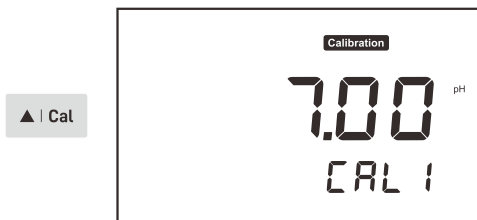

- 1.3 Rinse the pH electrode with distilled water, place the electrode into the pH 7.00 buffer solution, stir gently to create a homogeneous solution.

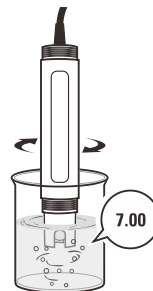

- 1.4 Press the **Enter** key, the meter begins the calibration.

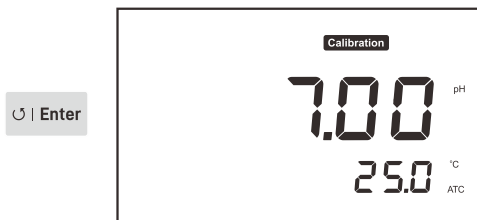

- 1.5 When the reading has stabilized, the meter will show **End** and return to the measurement mode.

2 Points Calibration

- 2.1 Ensure that you have selected 2 points calibration in the setup menu.
- 2.2 Repeat steps 1.2 through 1.4 above. When the first calibration point is completed, the display will show ----/CAL 2. The meter prompts you to continue with second point calibration.

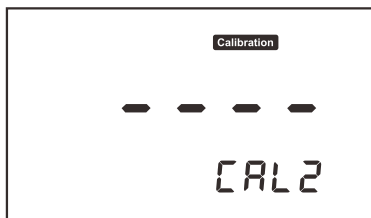

- 2.3 Rinse the pH electrode with distilled water, place the electrode into the next buffer solution (e.g., pH 4.01).

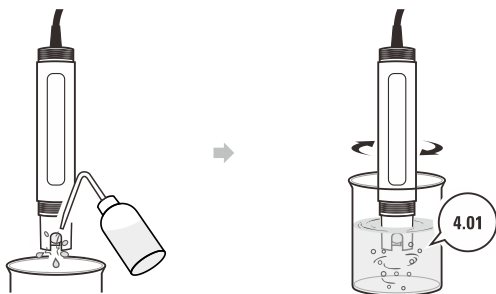

- 2.4 Press the **Enter** key, the meter automatically recognizes the buffer solution and begins the calibration.

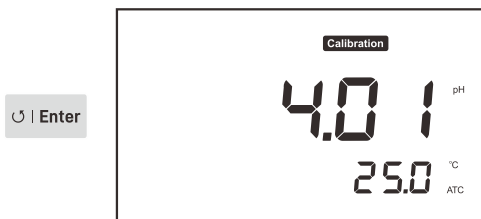

- 2.5 When the reading has stabilized, the display will show electrode slope and **End**. Calibration is completed.

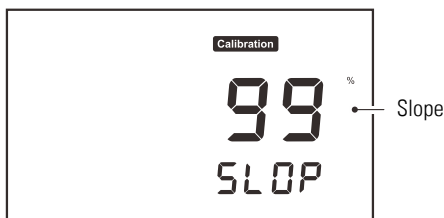

3 Points Calibration

- 3.1 Ensure that you have selected 3 points calibration in the setup menu.
- 3.2 Repeat steps 1.2 through 1.4 above. When the first calibration point is completed, the display will show 4.01/CAL 2. The meter prompts you to continue with second point calibration.
- 3.3 Rinse the pH electrode with distilled water, place the electrode into the pH 4.01 buffer solution and stir gently.
- 3.4 Press the **Enter** key, the meter begins calibration.
- 3.5 Wait for the reading to stabilize, the display will show electrode slope and 100.1/CAL 3 (or 9.18/CAL 3).
- 3.6 Rinse the pH electrode with distilled water, place the electrode into the pH 10.01 (or 9.18) buffer solution and stir gently.
- 3.7 Press the **Enter** key, the meter begins the calibration.
- 3.8 Wait for the reading to stabilize, the display will show electrode slope and **End**. Calibration is completed.



- During the calibration, if the display shows ---- indicating the meter is waiting for recognizing the pH buffer solution.
- If the display shows **Err** indicating the measured mV value for the current calibration point deviates by more than 60 mV from the theoretical value of the pH buffer. The calibration will not be accepted. Please check the pH electrode and ensure the buffer solutions are fresh and uncontaminated.
- If the calculated electrode slope is not between 70% to 110%, the pH electrode may need to be replaced.
- To exit the calibration without saving changes, press the **Off/Menu** key.

Measurements

pH Measurement

- 1.1 Press the **Unit** key until the display shows measurement unit "pH".
- 1.2 Place the electrode into the sample. Wait for the measurement to stabilize.

mV Measurement

- 2.1 Press the **Unit** key to switch the meter to "mV" mode.
- 2.2 Place the electrode into the sample. Wait for the measurement to stabilize.

Communication

The BI-620 meter uses a standard Modbus-RTU protocol. All of the data are character type (2 bytes). The response data ranges between -32767 to 32767, hexadecimal.

PC Command

Definition	Length of Byte	Data
ID address	1	0 × 01
Command	1	0 × 03
Start address	2	0 × 0001
Data number	2	0 × 0002
CRC16	2	0 × 95CB

Meter Response

Definition	Length of Byte	Data
ID address	1	0 × 01
Command	1	0 × 03
Data Length	1	0 × 0002
Data	N	0 × 02 0 × BC
CRC16	2	0 × E4DB

- If the response is 01 indicating the command is error.
- If the response is 02 indicating the address is incorrect.
- If the response is 03 indicating the byte length is incorrect.

Command 03: Read the data from the measurement

Command 04: Read the data from the setting

- ID: 0 × 01 (Fixed)
- 03: Definition
Address:
0 × 0000 - pH/ORP reading
0 × 0001 - Measurement unit (0 × 0001: pH, 0 × 0002: mV)
0 × 0002 - Temperature (Reading × 0.1)
- 04: Definition
Address:
0 × 0000 - Read the low alarm limit
0 × 0001 - Read the high alarm limit
0 × 0002 - 4.00 mA correspond to pH value
0 × 0003 - 20.00 mA correspond to pH value

For Example (Hexadecimal):

PC send: 01 03 00 00 00 02 C4 0B (Read the pH)
Response: 01 03 02 02 BC B8 95 (700)
PC send: 01 03 00 01 00 02 95 CB (Read the unit)
Response: 01 03 02 00 01 79 84 (pH)
The result will show 7.00 pH (700 × 0.01 pH)

Electrode Maintenance

In order to maintain an accurate measurement, the pH electrode needs cleaning and regular maintenance, cleaning procedure is as follows:

General Cleaning:

Remove the pH electrode from service and rinse the pH-sensitive glass membrane and liquid junction with clear water to remove deposits. If necessary, use a soft-bristled brush to clean electrode. Note, DO NOT scratch or break the glass membrane.

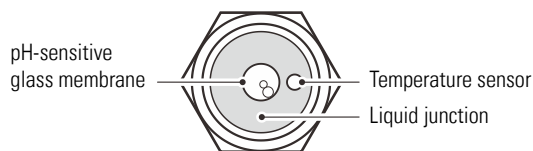

Oil or Grease:

Soak the pH electrode in detergent for 30 minutes. Rinse the electrode with clear water and soak in 3M KCl solution for 1 hour.

Lime or Mineral Deposits:

Soak the pH electrode in 0.1M HCl for 10 minutes. Rinse the electrode with clear water and soak in 3M KCl solution for 6 hours.

Protein:

Add 1% pepsin to 0.1M HCl solution. Soak the pH electrode in above solution for 15 minutes. Rinse the electrode with clear water and soak in 3M KCl solution for 6 hours.

Bacterial or Mold Growth:

Soak the pH electrode with dilute chlorine bleach. Rinse the electrode with clean water and soak in 3M KCl solution for 30 minutes.

After cleaning, refer to the **pH Calibration** section on page 4 to recalibrate the pH electrode.

If you do not use the electrode for long periods, store the electrode in 3M KCl solution. If this solution is not available, use 4.01 pH buffer or tap water.



Do not store the pH electrode in distilled or deionized water that will deplete the hydration layer of the pH-sensitive membrane and render the electrode useless.

Appendix

Troubleshooting

Fault	Cause and Corrective Action
Screen shows -----	Electrode dried out. Soak the pH electrode in 3M KCl solution at least 30 minutes.
	Measurement exceeded the maximum range. Check the electrode and sample.
Drifting erratic readings	Check whether electrode is contaminated, clogged or broken.
Screen shows Err	pH buffer problem. Use freshly prepared buffer solutions to calibrate the meter. The electrode has expired. Replace pH electrode.

Preparation of pH Buffer Solutions

The BI-620 meter is packaged with pH 4.01, 7.00, 10.01 buffer reagents required for calibration.

- Half fill a 250 ml volumetric flask with distilled water and add the pH 7.00 buffer reagent.



- Swirl the volumetric flask gently to dissolve the reagent and fill to the mark with distilled water.

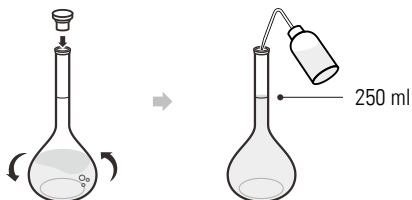

- Cap and upend the volumetric flask several times to mix the solution.

i Preparation of pH 4.01 and 10.01 buffer solutions are the same as above. Prepared buffer solution should be stored in hermetically sealed glass container and avoid direct sunlight.

Optional Accessories

Order Code	Description
IE-20T	Industrial pH electrode, 5 m (16 ft.) cable
PHCS-USA	pH 4.01, 7.00, 10.01 buffer solutions, 480 ml
PHCS-ES	Electrode storage solution, 480 ml

Meter Specifications

Model	BI-620
pH	
Range	-1.00 to 15.00 pH
Resolution	0.01 pH
Accuracy	±0.01 pH
Calibration Points	1 to 3 points
pH Buffer Options	USA (pH 4.01, 7.00, 10.01) NIST (pH 4.01, 6.86, 9.18)
Temperature Compensation	0 to 100°C (32 to 212°F), automatic
mV	
Range	-1000 to 1000 mV
Resolution	1 mV
Accuracy	±1 mV
Temperature	
Range	0 to 100°C (32 to 212°F)
Resolution	0.1°C (0.1°F)
Accuracy	±1°C (±1.8°F)
Calibration Point	1 point
Communication	
Signal Output	4 to 20 mA
Low or High Alarm	0.00 to 14.00 pH
Load	500 Ω
Communication Interface	RS485
Other Specifications	
Operating Temperature	5 to 50°C (41 to 122°F)
Storage Temperature	0 to 60°C (32 to 140°F)
Relative Humidity	< 80% (non-condensing)
Display	LCD, 70 × 45 mm (2.9 × 1.7 in.)
Power Requirements	DC 24V
Dimensions	96 (L) × 96 (W) × 75 (H) mm, (3.7 × 3.7 × 2.9 in.)
Weight	350 g (12.3 oz.)

Disposal

This product is required to comply with the European Union's Waste Electrical and Electronic Equipment (WEEE) Directive 2002/96/EC and may not be disposed of in domestic waste. Please dispose of product in accordance with local regulations at the collecting point specified for electrical and electronic equipment.



Warranty

The warranty period for meter is one year from the date of shipment. Above warranty does not cover the electrode and pH buffer solutions.

Out of warranty products will be repaired on a charged basis.

The warranty on your meter shall not apply to defects resulting from:

- Improper or inadequate maintenance by customer
- Unauthorized modification or misuse
- Operation outside of the environment specifications of the products

For more information, please contact the supplier.



Office: 4715 Castlewood St., Sugar land, TX 77479, USA

Tel: (+1) 346-762-7358

E-mail: banteinstruments@yahoo.com

Factory: 2185 Laifang Rd., Shanghai 201615, China

Tel: (+86) 21-6404-1598

E-mail: banteinstrument@hotmail.com

 www.bante-china.com



The information in this document is subject to change without notice.
Copyright © Bante Instruments Inc, 2022. All rights reserved.